

ORIGINAL PAPER

Open Access



# Sustainable development assessment of incentive-driven shared on-demand mobility systems in rural settings

Florian Heinitz\*

## Abstract

**Background:** In the light of the sustainable development goals, a set of operationalizable criteria quantifying societal benefits versus costs is needed to prepare for the introduction of an incentive-driven, high adoption shared on-demand mobility service in a rural transportation area. Aiming to reduce still-existing uncertainty about the impacts of a market entry and to balance substantial monetary incentives for suppliers of pooled rides with the progress in net GHG emission reduction and accessibility gain, the framework is applicable at the transactional and/or aggregate level.

**Results:** The presented set of indicators is decision-oriented, and applicable both at the transactional and macro level. Scenarios and user choice situations for two regulatory options of demand responsive transport—one in line with the current legislation in Germany, avoiding overlap with existing fixed-route scheduled public transport and one not strictly complementary which assumes direct competition—are formalized. By the help of a case study, the outcome of the different organizational models at three levels of incentivization can be systematically compared. The implementation effort of the assessment method is examined in view of the forthcoming sustainability compliance reporting in this sector.

**Conclusions:** A system-optimal constrained public private DRT deployment offers the opportunity of a reduction of uneconomic routes and parallel services upon selection of eligible rides. As shown, a crowding out of existing, publicly financed offerings in an unsaturated mobility market should not be the primary concern. At the contrary, resorting to supply-side incentives, a proportion of the high volume of solo car trips could be consolidated while levels of service improve in total. However, this may be associated with considerable expense, as demonstrated by the quantity structure of the provided case study.

**Keywords:** Sustainable transport, Sustainable development goals, Flexible integrated transport system, Demand-responsive transport (DRT), Mobility as a Service (MaaS), Ridesharing, Rural area, Germany

## 1 Introduction

Emerging technologies, the overarching concepts of Mobility as a Service (MaaS),<sup>1</sup> and fast-developing commercial activities, enabling among others on-demand road passenger transport, shared fleets and seat inventories on a

<sup>1</sup> MaaS aims “to fulfill individual mobility needs in a sustainable way by combining different transport services to seamless trips, offering an appealing alternative to owning and using a private car.” Amaral et al. [2]. “(,,) MaaS is an integrated transport service brokered by an integrator through a digital platform.(,,) The MaaS framework can operate at any spatial scale. (...)” [19].

\*Correspondence: heinitz@fh-erfurt.de

Fachhochschule Erfurt, University of Applied Sciences, Erfurt, Germany

larger scale, have automatically prompted the question of compatibility with the principles of sustainable development. Opportunities of modal integration through information technological convergence, openness to resource sharing, minuscule transaction costs through digitization, and network economies deemed favorable have nevertheless made platform-mediated, customer-centric, demand-driven ad-hoc (door-to-door) conveyance, vehicle hire and/or complementary services a reality. Especially in situations when public transport networks are financially unviable while solo travel with a private car is questionable from a traffic and environmental point of view, monetizable benefits may be realized. A combination of ridesharing with smart driving robotic car technologies [13] is likely to create a new unit cost floor [5].

Obviously, there is a considerable potential to reduce overall vehicle miles traveled by resorting to the empty car seats in the vast fleets not yet nearly utilized. Raising car occupancy levels would also indirectly contribute to the sustainability goals by reducing oil dependency with a view to the tense situation on the energy markets.<sup>2</sup> Furthermore, it is widely recognized that an incentivized vehicle sharing and bundling of road trips reduces flowing as well as resting traffic at an excellent cost–benefit ratio, and impacts (second) car ownership rates in the longer run [6, 50]. As demonstrated and underlined by the ITF [22], *MaaS* could positively contribute to mobility policy outcomes through a well-designed integration with existing public transport.

On the other hand, the argument of imminent sustainability problems is proffered against an admission of transport network companies (TNCs) and their fleet operations (“ride hailing” “ride sourcing”). There is mainly concern for the following four issues: (1) Generation of additional road traffic/emissions, (2) contesting the market position of (already subsidized) incumbent suppliers of public transport, (3) considerable extra spending upon service guarantees, (4) the loss of governance, social inclusion, reliability/resiliency, and undermining of standards hitherto (cf. [25, 37, 38]). Thus, market entry risks are greatly emphasized over their opportunities. Within the European Union, there is no unified approach. A liberalization of app-mediated conveyance is therefore handled inconsistently both nationally and regionally,<sup>3</sup> perhaps still with restraint and intentional delay overall.

<sup>2</sup> “An increase of around 50% in the average car occupancy across advanced economies in 1-in-10 trips and adopting best-practices to decrease car fuel use can save around 470 kb/d of oil in the short term.” [20].

<sup>3</sup> Although the revised German Passenger Transport Act (*PBeVG*) realistically takes account of varying parking locations of for-hire vehicles and waives obligations to return to the base, private operating licences are subject to a number of preconditions such as coordination with existing public transport, minimum tariffs, unit operating costs as a ceiling for driver compensations, barrier freedom etc.

Although a broad adoption of the whole spectrum of on-demand services is set to foster accessibility, to provide alternatives to private car ownership and expected to lower mobility costs, the “law in the action” in Germany and other countries has prevented a broad-based rollout. Updated federal legislation perpetuates a tight specification of private operations, e.g. through bundling quotas (cf. [16], as well as the traditional “regulatory market divide” [27]/2018). In effect, this confines the role to commuter carpooling, shared taxis as a last-mile feeder for public transport, and possibly to publicly run substitutive dial-a-ride service in the economically unattractive case of low and disperse demand. In fear of modal displacement, regional transport authorities and supra-regional information platforms are entitled to exclude new mobility services if a competitive situation with public transport arose. However, matching apps usually neither distinguish legal spaces nor accept geographic boundaries—the focus is on finding the best possible (multi-modal) option of conveyance. However, ride hailing (= solo taxi) and ride pooling (= factual ride sharing) are understood as hardly separable by-products of each other over time. Moreover, a desired distinction between “anyway” car trips and “intended detours” to carry passengers may prove to be pointless in practice—unless there is a way to tie the operator’s compensation explicitly to such conditions and track any approach ride.

Even under aforementioned legal conditions, efficiency gains are still possible. The presented research aims at a differentiated approach of a cautious market opening which reconciles the opportunities of incremental on-demand services in rural/sub-urban setting with the requirements of transport sustainability. It proposes an anticipatory case-related assessment method as an objectifiable basis to understand under what conditions is their introduction still a winning proposition on balance, with benefits exceeding additional financial and ecological burdens.

The remaining paper is divided into four parts. Section 2 examines the substantial literature to search for solutions and to integrate ideas from related approaches to assess ridesharing, DRT, and *MaaS* from a sustainability perspective and/or of relevance to rural study areas. To achieve a modal integration through incentivized ridesharing while taking on the critical issues preceding a (limited) market approval, the methodological part of the sustainable development assessment is then elaborated in Sect. 3, to touch upon its practical application aspects in Sect. 4. The final Sect. 5 provides conclusions and policy recommendations.

## 2 Literature review

The literature on assessing new mobility services has undoubtedly become very extensive.

As early as 2012, Manzini & Paresci demonstrated an operational decision-support system for the combined ride matching and shared-vehicle routing problem from a mobility manager's perspective, emphasizing the effectiveness gained through hierarchical clustering techniques for pool formation in connection with vehicle rerouting. Häme [15] proposed a number of mathematical models that can be used to simulate the operations of DRT services in a wide range of scenarios. Bahat and Bekhor [3] laid technical foundations in coupling mode choice and traffic assignment models which included ridesharing. Mounce et al. [33] provided a rural case study on combining FRS with demand-responsive elements in Flexible Integrated Transport Systems (FITS). Hensher et al. [18] explained how MaaS fits into the transport landscape, also emphasizing opportunities of modal integration and subsequent efficiency gains, depending on the geographic context of the operation area.

Daganzo and Ouyang [7] generically compared the capabilities of different types of DRT, however, assumed a synthetic, steady and uniformly distributed demand in space and time. Middleton, Schroeckenthaler et al. [32] comprehensively described the user behavior and its descriptiveness with or without presence of on-demand ride hailing, underlining the decisive role of incentivization for app-based sharing. The work of Storch et al. [43] is notable in this regard as it scrutinized the interaction between incentive structures and adoption of balance requests.

Further to this, findings comprise the trip characteristics where TNC users have the highest inclination to share rides as well as the sharing probability's elasticities with respect to monetary incentives and reduced travel times of high-occupancy vehicles. Empirical evidence of an urban-rural gap in terms of a detriment of revenue and lower achievable utilization levels of DRT, was provided for example for minibus services in South Africa by Simons et al. [41]. The forward-looking work of Imhof et al. [21] detailed a rural transport scenario with shared autonomous vehicles. Jacob et al. [23] dealt with algorithms of effective pricing for ride-sharing portals. Early on, the Thredbo series of conferences on competition and ownership in land transport was dedicated to topics connected with DRT and "fifth mode" supply, such as institutional reforms, extent of funding by local authorities, and procurement strategies. Continuing to include investigation of DRT, its topical contributions give policy insights and reflect favorable solutions from a transportation economics view point also for rural/disperse demand

settings. For example, Nocera and Tsakarestos [35] have analyzed successful trial runs of DRT systems in Germany, deriving ways to efficiently integrate traditional transport into virtual "mobility centers". Mounce et al. [34] emphasize the roles of frameworks and smart mobility towards solving rural mobility problems. Haferkamp and Ehmke [14] further develop dynamic fleet management in ridesharing to increase acceptance rates through anticipatory capacity allocation depending on temporal, geographic density.

To establish appropriate indicators and performance models, subject-specifically interpreting the aim of sustainability, has been one of the foremost topics of the past two decades' transportation research [51]. Conceptually, there is a broad distinction between "strong sustainability" (e.g., [36]) which insists on the primacy of the ecological sustainability, in particular on imperative sectoral GHG emission budgets, and the notion of "weak sustainability" (e.g., [47]), which recognizes a system of all relevant, generally agreed but partly competing goals (e.g., "Triple Bottom Line"), seeking to meet present societal needs without limiting the future opportunities of subsequent generations.

Transport-sector specific sustainability indicators have been developed for more than a decade. Examples of this are the work of Dobranskyte-Niskota et al. [9] and Eva et al. [11]. Yin et al. [49] were among the first to adopt (still aggregated) performance measures such as unit private vehicles as a network congestion ratio to comprehensively analyze the impact of ridesharing for the Paris region. Yang et al. [48] showed a systematic indicator set generation, applicable to new mobility service for a transport and urban design process. Litman [30] itemized development indicators with a clear linkage to the supported policy goals. Khavarian-Garmsir et al. [25] deployed the "weak sustainability" concept in a meta-study to systematically cover positive and negative social, economic, and environmental impacts of ride-hailing. The authors also pointed to remaining areas of uncertainty, such as the car manufacturing industry. In practice, TNCs are known to deploy their own success metrics from a provider's standpoint. Pangbourne et al. [37] counter this one-sided technical view by raising a number of issues while critically examining "MaaS performance promises" versus unanticipated effects, calling for a stricter MaaS governance in the end.

What still appears to be missing in the literature so far is a generalizable examination of a choice situation enlarged by integrated on-demand services in a rural niche market, in connection with consistency checks of the prospective system states with the social, ecological, and financial objectives of sustainability in the run-up to a possible "Emerging MaaS" launch. Understandably,

since the agreement with multi-dimensional societal goals constitutes the fourth and highest of MaaS levels of integration (cf. [19]).

### 3 A case-related sustainable development assessment

Given the general contrast between rural and urban transport areas, the initial situation and value propositions with regard to an introduction of demand-responsive transport (DRT, also referred to as on-demand mobility service) and prospective adoption of MaaS schemes appear to differ fundamentally in a rural setting. The starting hypothesis is that the effect from accessibility and efficiency gains from incentivized car trip consolidation for rural and suburban regions is more pronounced than the increase the intensity of modal competition. It is based on the following considerations from the observation of rural Germany:

- In rural areas public transport cannot serve as the backbone. Small patronages beyond school transportation, soaring deficits of operators and the limitations of given fixed-route scheduled (FRS) transport technologies in connection with complex legal obligations, resulting in infrequent, unproductive routes and the incapacity of profound supply changes, suggest that it is at least partly unsustainable.
- Given the incompleteness of public transport supply at many requested yet “thin” origin–destination pairs in combination with requested departure time windows, no economic alternative to the private car can be created by FRS regional bus technology.
- There is no blanket answer as to what extent the above-stated supply gap can be bridged by DRT services—especially when it comes to round trip or trip chain completion.
- Unfavorable network economies make the prospect of on-demand services becoming a fully-fledged alternative to scheduled public transport seem implausible.
- Traditional dial-a-ride services are negligible in terms of transport performance, such that there is no precursor of demand responsive transport that could be displaced.
- Throughout rural areas, road congestion effects are mostly irrelevant. Thus, a traffic mitigation benefit from trip bundling such as in conurbations cannot be expected. On the other hand, travel times will not deteriorate upon additional vehicle fleet operations.

With the advancement of DRT, the field trial of it is a welcome subject of empirical research (e.g.—[24]), but not so where market approval is still being sought. In

view of the ambitious task in a rural setting and above-stated caveats, the lack of a manageable a priori assessment of sustainability still proves to be a weak point. Admittedly, there is no substitute for practical testing—but this is precisely where great restraint, also due to tight public transit-related budget funds, is exercised.

Even if the basic functioning can be shown—both theoretically and in practice—for different investigation areas and countries, the achievable effects on car trip consolidation and the mobility gain in the absence of market liberalization steps and/or incentivization remain rather modest. By means of remuneration incentives beyond the coverage of operating costs, the supply of driving services can be increased from its low initial level to the critical mass, eventually a certain saturation point or break-even of a localized matching platform.

The research approach at hand therefore assumes an admission and targeted co-financing of on-demand mobility services in public–private partnership as the reference to two principal regulatory options described below. Incentive-driven rural DRT—as an amendment and a partial substitute to FRS operations—make the best use of the locally available transport resources, that is, floating private car and passenger van fleets of substantial size. Since the conveyance provision is partly bought by subsidies, resulting in additional budget requirements. These must be weighed against the benefits. The aim to prepare for the proliferation, the necessary transformation process, and to overlook the relevant implications of such a flexible integrated transport system (FITS) suggests an evaluation framework to assure the compatible with a sustainability system of objectives.

The intended exploration of opportunities for transformation leads to the idea of a generalizable approach of specifying transport areas receptive for an on-demand mobility service use case—governed by indicators of sustainable development goals (SDGs) from the outset. How can achievements of a market entry in a small rural transport area—about the size of a county in Germany—be assessed when reproducing a sustainability system of objectives? To address the research question heralding expected comprehensive reporting requirements, the vast variety of quantifiable indicators is narrowed down to a manageable set—as a basis for decision-making at both transaction and aggregate level.

Notwithstanding the emphasis and considerable ecological pressure to act, a responsibly undertaken redesign of transport systems embraces further essential policy fields. Trade-offs between objectives such as the improvement of accessibility, affordability and efficiency—given the limitations of public budgets—are required within the

general context of sustainable development. To address the U.N.'s sustainable development goals [44], namely.

- SDG 10 to “reduce inequalities within and among countries”—focusing also on rural areas
- SDG 11 to “make cities and human settlements safe, resilient and sustainable”, to foster sustainable transport, to “increase access to public transport”
- SDG 13. to “take urgent action to combat climate change and its impacts”,

their sets of binding indicators for a global measurement and monitoring (cf. [45] and [46]) were analysed. It became apparent that for the present case more specific and disaggregated indicators must be established for providing direct decision support. Nevertheless, the tripartite design balancing social, environmental, and economic target dimensions (cf. [25]) shall be adopted to weigh societal benefits of the offerings against the societal costs. Analogous to this, the German Automobile Club ADAC groups its sustainability-oriented “Mobility Index” in five dimensions (1) Climate and environment (2) transport safety and reliability (3) affordability (4) availability [1].

Sustainability acts as a driver of a more resolute supply expansion and an evaluation yardstick at the same time. Accessibility and carbon footprint performance indicators are essential. To this end, a transport supply–demand model to assess the SDG and GHG reduction target<sup>4</sup> conformity by appropriate parameters first of all needs to reflect the relevant market and the enlarged choice situation. Conceptualizing the regional transport market transformation in a generic way means to cover the family of new mobility offerings with their interaction path. For this reason, special attention is being paid to the choice set formation in prospect.

At the level of fulfillment time windows of origin–destination pairs, a supply–demand equilibrium is postulated and compared with the initial situation. To limit the complexity, non-transport aspects (such as compliance with social regulations) and secondary effects (such as fixed-route scheduled network consolidation, altered destination choice) will not be stressed here. The approach exploits the fact that all *MaaS/DRT* transactions are digitally recorded. Thus, an immediate check of eligibility (i.e., goal conformity) is at least technically feasible. A twofold planning framework will account for two different regulatory approaches, to be referred as Options I and II.

The two principal regulatory options and their respective choice situations will be analyzed first (3.1). Then the model assumptions will be stated, key variables and the delivery of on-demand conveyance specified (3.2). An analytically derived set of indicators is compiled to form the proposed assessment scheme (3.3). The indicators can be deployed individually, in combined form to constitute an index, or with target values as constraint goals in terms of a checklist.

### 3.1 Regulatory options, choice and transitions set formation

The detailed consideration of the altered modal choice situations in the course of an on-demand service introduction suggests a distinction of two regulatory options that may be applied in connection with subsidization schemes at different areas/time horizons. *E.R.U.* denotes the traveler's expected received utility  $\tilde{U}$  when facing the entire choice situation of each option.

*Option I* (Fig. 1) responds the current legal situation in Germany, where ridesourcing must not be operated freely and in direct competition. By integrating on-demand services as an aligned complementary, subordinate part of public transport, a provider could be commissioned to address the residual demand unsatisfied by fixed-route scheduled public transport only. From this, an obvious sequential planning approach with a staggered supply arises, set to minimize the overlap within a flexible integrated transport system (cf. [17]): A certain proportion of the first demand residual unassignable to FRS at an acceptable service level can be serviced by carpooling on an operating cost sharing basis, thus producing a second residual. With the help of monetary incentives in excess of the operating cost ceiling, ride pooling (=tied to the conditions of extra passengers) could cover the demand in part, leaving a third residual which is to be addressed by ride hailing/solo taxi service. In effect, there is a cascading, constrained choice process. Ideally, every origin–destination-time window combination only features disjunctive public offering out of  $\{\bar{2}, 2A, 2B, 2C\}$ . As a consequence, the cost–benefit analysis would have to deal with the marginal effects.

*Option II* (lower part of Fig. 2) goes beyond what is currently legally possible. It stands for a state of liberalization and competitive environment, in combination with selective incentives in order to encourage gap-filling pooled car trips and alternatives to solo driving in private cars. Here, the family of shared on-demand services in their three essential forms 3, 4, 5 functions as a non-aligned substitutive as well as complementary transport mode in its own right and can be accessed ubiquitously through a simultaneous mode choice decision. The full 5-ary choice

<sup>4</sup> The German climate protection law sets a sectoral target of 85 million metric tons of CO<sub>2</sub> equivalents by 2030 for transport as a whole. This is roughly half the amount emitted in the pre-Corona year 2019.

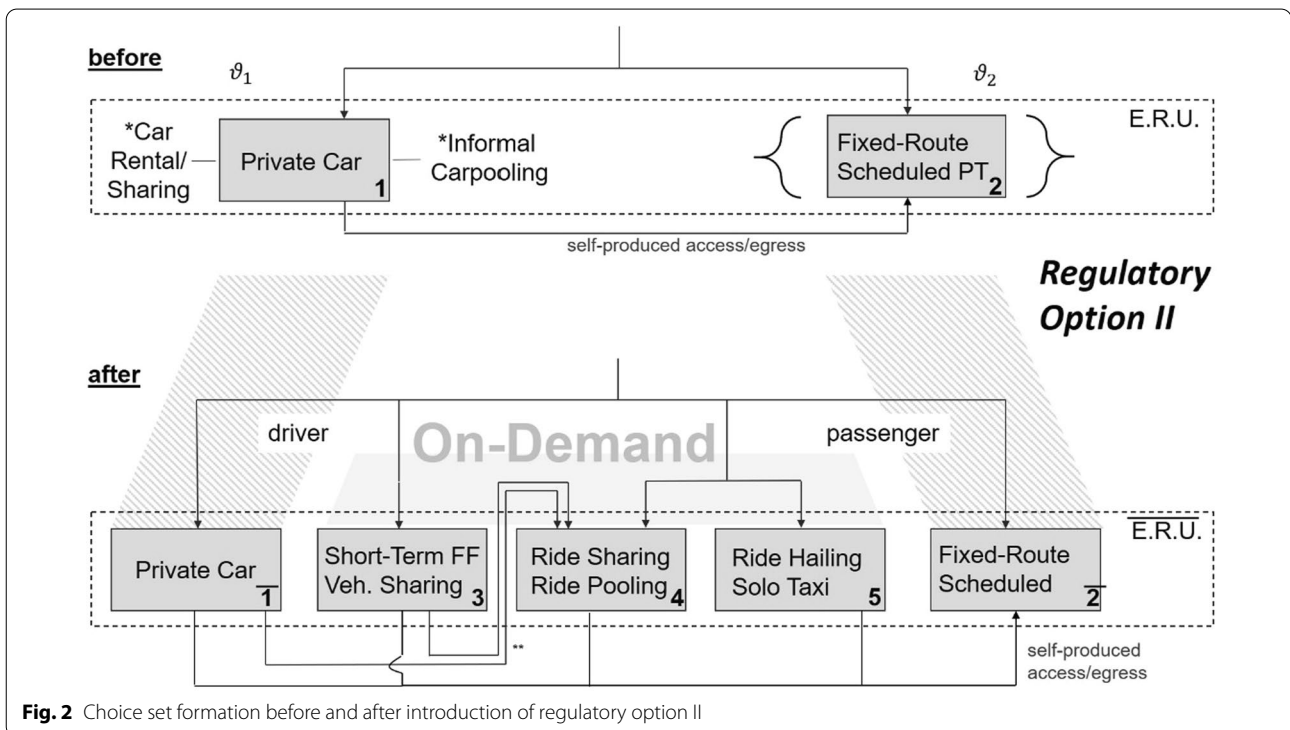
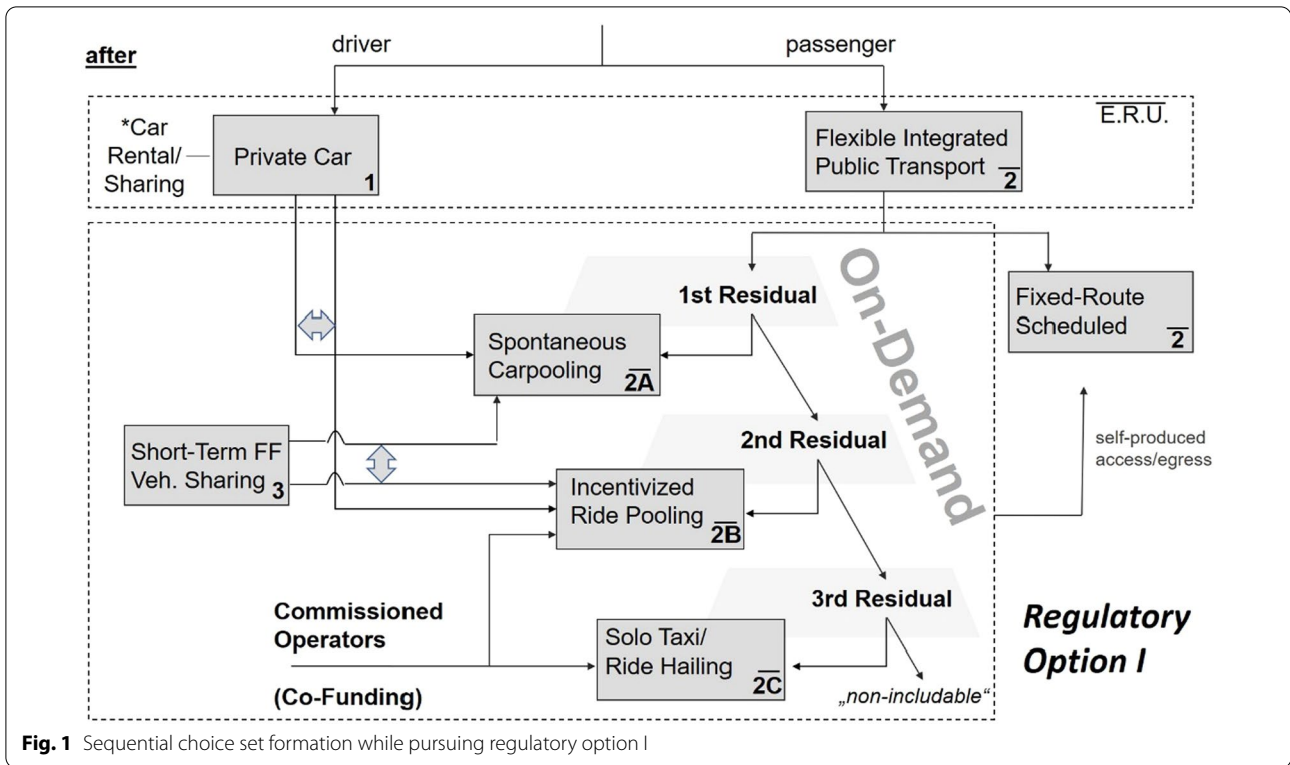

**Table 1** Exhaustive case discrimination of  $2 \times 18$  possible transitions

Scenario	Regulatory Option I			Regulatory Option II		
	(Solo) Car $\bar{1}$	FITS—public Tpt		(Solo) Car $\bar{1}$	FRS $\bar{2}$	On-demand 3, 4, 5
Final choice set $\bar{C}$						
Initial choice set $C = m$		FRS overline2	On_Demand 2A $\vee$ 2B $\vee$ 2C			
(a) Elective user, PT available {1, 2} $m^* = 1$ chosen	12a-1-1	12a-1-2	12a-1-2A $\vee$ 12a-1-2B $\vee$ 12a-1-2C	12a-11-1	12a-11-2	12a-11-3 12a-11-4 12a-11-5
(b) $m^* = 2$ chosen	12b-1-1	12b-1-2	12b-1-2A $\vee$ 12b-1-2B $\vee$ 12b-1-2C	12b-11-1	12b-11-2	12b-11-3 12b-11-4 12b-11-5
Elective user, PT unavailable $\sigma_L = 0$ & $\vartheta_1\%$ Car Captive {1}	1-1-1	–	1-1-2A $\vee$ 1-1-2B $\vee$ 1-1-2C	1-11-1	–	1-11-3 1-11-4 1-11-5
$\vartheta_2\%$ PT Captive/Car unavailable {2}	–	2-1-2	2-1-2A $\vee$ 2-1-2B $\vee$ 2-1-2C	–	2-11-2	2-11-3 2-11-4 2-11-5

**Table 2** Key to symbols used

$\{(i, j)\}$	Sets of O-D pairs	$L, L$	Level of service vector, agreed minimum~
$\{\tau\}$	Discrete fulfillment time windows	$d, \delta, \delta_{ij}^*$	Road distance, specific detour factor $\geq 1$ , detour factor $i-j$ at equilibrium
$\pi, \pi'$	Trip party size, extra car passengers taken	$\alpha, \alpha_0, \alpha_1$	Ridesharing supply adoption function and functional parameters
$T, \bar{T}$	Person trip count per period, before/after DRT introduction	$c_O, c_{Eb}, c_{E\pi'}$	Unit vehicle operating, external unit costs
$\vartheta$	Proportion of non-elective users	$r_0, r_1$	Passenger transport compensation (fix, unit)
$P$	Choice probability	$w_P, w_D$	Passengers'/drivers' willingness-to-pay
$V$	Systematic/observable utility	$C, \bar{C}$	Choice sets before, after market entry
$B$	Budget needed to incentivize routes of public interest	$\sigma_L, \sigma_T$	Step functions: relevance of supply, demand
$m$	Modal choice option	$S$	Supplier surplus if ridesharing is adopted
$R, R', R''$	$(i, j, \tau)$ Residuals, Option $l$	$\bar{U}$	Expected received utility (E.R.U.)

set (upon availability) is  $\{\bar{1}, \bar{2}, 3, 4, 5\}$ . Note that options  $\bar{1}, 3$  indirectly influence the supply side of option 4.

Initially (upper part of Fig. 2), for both Options I and II, there is—to a good approximation—a binary choice situation between private car and fixed-route scheduled (FRS) public transport. If there is no acceptable FRS offer and other/upcoming choice options such as taxis, free-float car sharing or casual carpooling are widely negligible, the private car is practically in a monopoly position. Given a rural setting, that case is so numerically relevant that it has to be treated separately in the following. Moreover, for each of the choice options {1, 2} proportions of captives have to be considered. For an exhaustive consideration of all conceivable case constellations, the initial and final choice decisions can now be combined in a cross-table (Table 1). There are 18 cases of possible transactions discriminated and quantified for each option.

**3.2 Model assumptions and formalization**

The key to symbols is provided in Table 2. The following assumptions underlie the model:

The investigation area is an isolated regional traffic region, represented by a system of zones  $\{i\}$  and resulting origin–destination pairs  $\{(i, j)\}$ , each of the latter further characterized by the fixed total trip count  $T_{ij}$ , disaggregated into  $T_{ij\tau\pi}$ —the trips per fulfillment time window  $\tau$  and with party size  $\pi$ , the available modal choice set  $\{m\}$ , the reference road distance  $d$ , and the respective level of service vectors  $\{L_{j\tau}\}$  for private cars and public transport. The latter are obtained from performing route search at the respective infrastructure or timetable graphs, linked to each zone by designated connector nodes. Let  $\delta_{ijj'}$  be the detour factor if a vehicle of O-D pair  $(i', j')$  is routed such that it includes the leg  $(i, j)$ .

To limit the complexity at first any transport mode of  $\{1/\bar{1}, 2/\bar{2}, 2A, 2B, 2C, 3, 4, 5\}$  is assumed to have a uniform

fleet with distance-based unit operating costs  $c_O$  and unit external costs  $c_{Eb/\pi'}$ . Even though an obvious solution to provide access and egress to public transport by the newly introduced services, multimodal trips were not considered at this point. Initially, there are just two available modes—private car for solo drive or “family pool” (1) and FRS public transport (2). With the captive car and transit users  $\vartheta_1$  and  $\vartheta_2$  segmented a priori, a fraction  $1 - \vartheta_3$  of remaining elective users  $1 - \vartheta_1 - \vartheta_2$ , generally willing to adopt DRT upon preregistration, undergoes the mode choice. A multinomial logit (MNL) provides the choice probabilities  $P_{ij\tau\pi}$ .

Deterministic choice set generation rules for the two regulatory options are applied. A de-minimis filtering function  $\sigma_T$  for O-D pairs assures that an addressable demand exists at all. The relevant market—at the initial choice level of Option I and generally in case of Option II is

$$\{i\} \times \{j\} \times \{\tau\} \setminus \{(i, j, \tau) | \sigma_T(T_{ij\tau}) = 0\}. \tag{1}$$

A further step function  $\sigma_L$  is used to block any O-D pair—fulfillment time window  $\tau$  combinations where a transport service fails to reach an agreed minimum service level  $L$ , i.e.,

$$\sigma_L(L) = \begin{cases} 1 & \leftarrow L \geq L \\ 0 & \leftarrow \text{else} \end{cases}. \tag{2}$$

$\sigma_L$  can be specified, e.g., by an upper bound of transfers, out-of-vehicle time, and/or multiple of the car travel time. If this condition is not met, the respective transport service is marked as unavailable. The residuals  $R, R', R''$  faced at subsequent choice levels in case of Option I are:

$$R := \left\{ (i, j, \tau) | \sigma_T = 1 \wedge \sigma_L(L_{ij\tau}^{(2)}) = 0 \right\} \tag{3}$$

$$R' := \left\{ (i, j, \tau) | (i, j, \tau) \in R \wedge \sigma_L(L_{ij\tau}^{(2A)}) = 0 \right\} \tag{4}$$

$$R'' := \left\{ (i, j, \tau) | (i, j, \tau) \in R' \wedge \sigma_L(L_{ij\tau}^{(2B)}) = 0 \right\} \tag{5}$$

In addition to granting market access, the regulation also covers the maximum compensation per vehicle kilometer  $r_1$  and the applied incentive scheme for insufficient FRS routes ( $L < L$ ) as well as routes of public interest. Here, the users are to be equated with private car users. That is, only costs beyond  $c_O$ , to be shared by the  $\pi'$  extra car passengers ( $r_0$ /passenger kilometer, flat fee of  $r_1$  per ride), have to be borne by private households.

The minimum compensation for pooling a car trip, i.e. taking passengers at relation  $(i, j)$  during time window  $\tau$

has to balance the operating cost including the approach ride  $(i', i)$  and follow-up leg  $(j, j')$  and the driver’s valuation deteriorating level of service.

$$c_O \cdot d_{ij} \cdot \delta_{ij'j'\tau} + w_D \left( L_{ij'j',\tau}^{(RS)} L_{i'j',\tau}^{(1)} \right) \tag{6}$$

It is assumed here that the driver is exempt from accident cost carrying additional passengers. Let  $\alpha$  be an empirical sigmoid-shaped function describing the propensity  $[0 \dots 1]$  to supply a lift

$$\alpha(i, j, \tau, i', j', \pi', r_0, r_1) = \frac{\alpha_0}{1 + \exp(-\alpha_1 \cdot S)} \tag{7}$$

where  $S$  denotes the supplier’s individual surplus for this specific constellation

$$S_{ij'j'\tau} = (d_{ij} \cdot r_1 + r_0) - c_O \cdot d_{ij} \cdot \delta_{ij'j'\tau} - w_D \left( L_{ij'j',\tau}^{(RS)} L_{i'j',\tau}^{(1)} \right) \tag{8}$$

given by the difference of paid compensations, vehicle operating cost and the driver’s valuation deteriorating level of service. By virtue of the respective level of compensations, an O-D pair  $(i, j)$  at time  $\tau$  is at supply–demand equilibrium if sufficient seats are offered/taken

$$\sum_{i',j'} \pi' \cdot \alpha(i, j, \tau, i', j', \pi') \cdot T_{i'j'\tau} = T_{ij\tau} \cdot P_{ij\tau}^{(RS)} \cdot \pi \tag{9}$$

The passengers’ willingness to pay matches the fare, linearly increasing with O-D distance:

$$(d_{ij} \cdot r_1 + r_0) = \pi' \cdot w_P \left( L_{ij,\tau}^{(RS)} \right) \tag{10}$$

The more incentives, the more detours will be accepted. At equilibrium, the average detour factor needed should be  $\delta_{ij\tau}^*$ , the average surplus is  $S_{ij\tau}^*$ , the minimum surplus is  $\min_{i',j'} S_{ij'j'\tau}$ .

### 3.3 Specification of indicators

To measure the SDG conformity of a possible market entry, the key indicators under closer examination are the share of feasible mobility options, net subsidy requirements, the balance of external costs, monetized user benefits, the effect on the collective modes’ market shares and average car occupancy, as well as the expected gain in utility. These are described now:

#### 3.3.1 Share of feasible public mobility options

The demand-weighted share of public mobility options for requested O-D pairs and time windows, i.e., feasible  $(i, j, \tau)$  combinations realized by modes that do not



presuppose car ownership and exceeding the minimum accepted level of service, forms the first indicator:

$$\frac{1}{\|i\|^2 \|\tau\|} \sum_{i,j,\tau} T_{ij,\tau} \sigma_{\mathbf{L}}(\max_{m \in \bar{C}}(\mathbf{L}_m)) \quad (11)$$

At the level of traffic zones, it describes the spatial equity between settlement areas.

**3.3.2 Budgetary requirements**

The budget used to boost private demand to sustain the residual DRT routes R—to be offset by fare revenue—is

$$B = \sum_R B_{ij\tau} = \sum_R T_{ij\tau} \cdot P_{ij\tau}^{(RS)} \cdot (d_{ij} \cdot (r_1 - c_O) + r_0) \quad (12)$$

To prevent an overflow of disbursed subsidies, a demand-based upper limit constraint may be imposed on the  $B_{ij\tau}$  and/or  $B$  less revenue, which nevertheless results in a rationing of supply.

**3.3.3 Balance of external costs and GHG emissions**

The unit external costs considered are per vehicle kilometer at average occupancy ( $c_{Eb}$ ) and per extra passenger taken ( $c_{E\pi'}$ ). Among all the supplying O-D pairs and provided that the vehicle receiving passengers would have covered  $d_{ij'}$ , there are net external costs savings to be differentiated:

$$\Delta c_{E,ij'j'}(\pi') = c_{Eb}^{(1)}(d_{ij} + d_{ij'}) - (c_{Eb}^{(RS)} \delta_{ij'j'} + \pi' c_{E\pi'}^{(RS)}) d_{ij} \quad (13)$$

To realize net savings, detour factors and thus the set of eligible ( $i', j'$ ) are constrained by

$$\delta_{ij'j'} < \frac{1}{c_{Eb}^{(RS)}} \left( \frac{c_E^{(1)}(d_{ij} + d_{ij'})}{d_{ij}} - \pi' c_{E\pi'}^{(RS)} \right). \quad (14)$$

The maximum saving is obtained by searching the appropriate O-D pair, such that one obtains

$$\max_{i'j'} (\Delta c_{E,ij'j'}(\pi')). \quad (15)$$

On a macroscopic scale, the per-km external costs and emissions the effective net difference of the vehicular performance before and after the introduction of shared on-demand services is the decisive criterion.

**3.3.4 User benefits of elective demand**

For simplicity, a trip party  $\pi'$  is only jointly transported. Fixed linear passenger pricing is assumed, consisting of a flat fee equal to  $r_0$  and a unit price per vehicle kilometer equaling  $c_O$ . User charges could be further reduced on a target-group-specific basis by providing subsidies.

With the price fixed, the choice probability is merely a service level variate—taking a solo car trip as a reference:

$$P_{ij\tau\pi'}^{(RS)} = \exp V(r_0, c_O, \mathbf{L}_{ij\tau}^{(RS)}, \mathbf{L}_{ij\tau}^{(1)}) / \sum_{m \in \bar{C}} \exp V_m \quad (16)$$

Monetary appreciation of the user benefit gained from improved level of service, considering a probability of choosing ridesharing, can be expressed by the consumer surplus in every ( $i, j, \tau$ ) combination—according to an adapted “Rule of Half” formula. The two cases of Option I—where only the residual R is affected—and II must be distinguished.

$$\text{Option I} \quad \frac{1}{2}(1 - \vartheta_1 - \vartheta_2) \cdot (1 - \vartheta_3) \sum_{\substack{i,j,\tau \\ (i,j,\tau) \in R}} T_{ij\tau\pi'} \cdot P_{ij\tau}^{(RS)} \cdot w_P(\mathbf{L}_{ij,\tau}^{(RS)}, \mathbf{L}_{ij,\tau}^{(2)}) \quad (17)$$

$$\text{Option II} \quad \frac{1}{2}(1 - \vartheta_1 - \vartheta_2) \cdot (1 - \vartheta_3) \sum_{i,j,\tau} T_{ij\tau} \cdot P_{ij\tau}^{(RS)} \cdot w_P(\mathbf{L}_{ij,\tau}^{(RS)}, \mathbf{L}_{ij,\tau}^{(2)}) \quad (18)$$

The FRS service level is used as a reference here. A separate term describing the benefit for previous private car users is omitted here, assuming that a loss of convenience and somewhat increased travel time is offset by the cost savings.

**3.3.5 Market share of collective modes**

Option I implies an increase by definition, as ( $i, j, \tau$ ) combinations with sufficient FRS service level are not affected, thus

$$P_2 + P_{2A} + P_{2B} > P_2. \quad (19)$$

In the case of Option II (omitting option “3” car sharing for simplification), the ratio of market shares after/ before *MaaS* market entry is

$$(P_2 + P_4) / P_2. \quad (20)$$

On the premise of unchanged FRS mode characteristics, i.e.  $V_2 = V_2$ , (20) can be rewritten as

$$\frac{P_2 + P_4}{P_2} = \frac{(\exp(V_2) + \exp(V_4))(\exp(V_1) + \exp(V_2))}{\exp(V_2)(\exp(V_1) + \exp(V_2) + \exp(V_4) + \exp(V_5))} = 1 + \exp(-V_2)(\exp(V_4) \cdot P_1 - P_5) \quad (21)$$

The lower FRS public transport’s systematic utility in the initial state and the higher the original solo car market

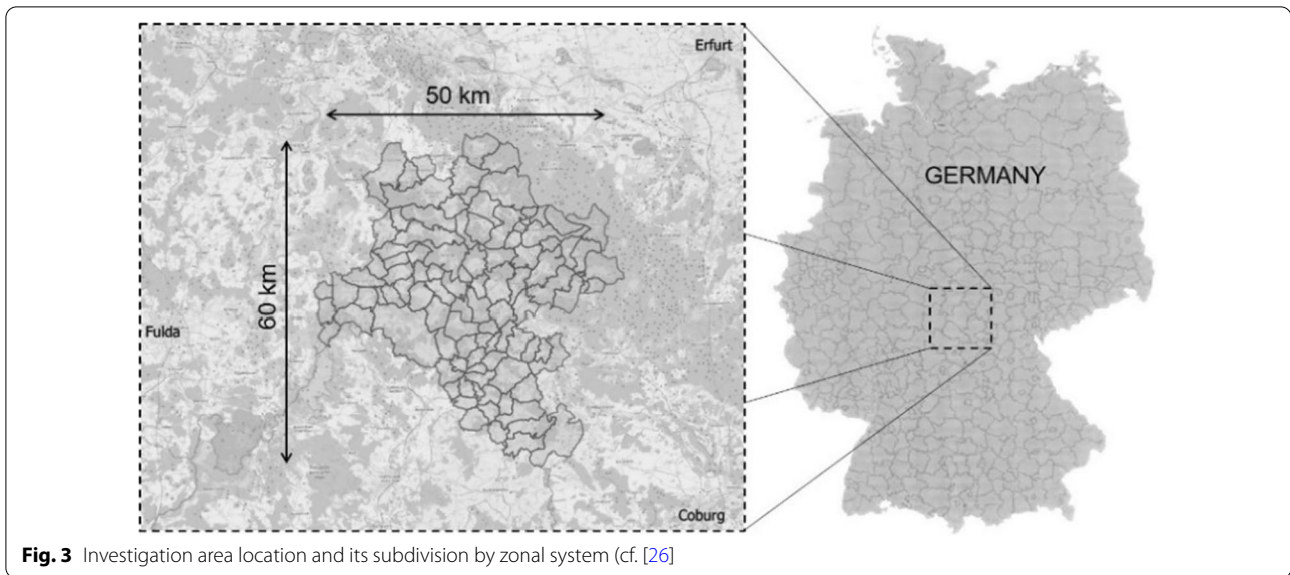

**Fig. 3** Investigation area location and its subdivision by zonal system (cf. [26])

share, the higher the growth factor—as long as  $\exp(V_4) \cdot P_1$  exceeds share  $P_5$ .

### 3.3.6 Operational efficiency of on-demand services

As stated by Liebchen et al. [29], the ratio of the passenger transport performance (in Pkm) to the vehicle performance (in Veh.km) is the appropriate measure of the operational efficiency.

For ridesharing only, this is nothing but the mean car occupancy level, accounting for detours:

$$\frac{(\pi + \pi')}{\pi \delta_{ij}^*} \tag{22}$$

A before and after comparison of private vehicle utilization corresponds to the demand-weighted ratio of

$$\frac{\sum_{ij\tau\pi} T_{ij\tau\pi} \cdot \left( P^{(1)}\pi + \frac{P^{(RS)}(\pi + \tilde{\pi})}{\delta_{ij}^*} \right)}{\sum_{ij\tau\pi} P^{(1)}\pi T_{ij\tau\pi}}, \tag{23}$$

which rises through promotion of ridesharing according to the expression ( $\tilde{\pi}$  is the expected value of rideshare passengers taken) and the avoidance of detours upon approach rides.

### 3.3.7 Gain in expected received utility

Assuming constant demand in terms of trip count, a comparison of the gain in expected received utility quantifies the appreciation of the added mobility options. The exponential of the differences in  $\tilde{U}$  is formed and summed over all combinations ( $i, j, \tau$ ):

$$\exp(\Delta \tilde{U}) = \sum_{ij\tau} \exp \left( \ln \sum_{m \in \bar{C}} \exp(V_m) - \ln \sum_{m' \in C} \exp(V_{m'}) \right) \tag{24}$$

The different choice sets  $\bar{C}$  of Options I and II need to be discriminated and can be simplified as

$$\begin{aligned} \text{Option I } \exp(\Delta \tilde{U}) &\sim \sum_{R \setminus R'} \frac{\exp(V_{2A})}{\exp(V_1) + \exp(V_2)} \\ &+ \sum_{R' \setminus R''} \frac{\exp(V_{2B})}{\exp(V_1) + \exp(V_2)} \end{aligned} \tag{25}$$

$$\text{Option II } \exp(\Delta \tilde{U}) \sim \sum_{ij,\tau} \frac{\exp(V_3) + \exp(V_4) + \exp(V_5)}{\exp(V_1) + \exp(V_2)}. \tag{26}$$

## 4 Practical application

Using the example of the quantity structure taken from a passenger transport model of a specific investigation area (4.1), in this section the previously presented model apparatus will be instantiated by the initial situation and exploring the scenarios of the two regulatory options impacting the current transportation practice. (4.2). The discussion (4.3) addresses the contribution to SDG targets, the implementation effort of this method, and further policy issues.

### 4.1 Investigation area and initial quantity structure

The investigation area of Schmalkalden-Meiningen in the center of Germany, depicted in Fig. 3, is considered prototypical in terms of its peripheral location, polycentricity, and medium-to-low population density. The renewed

**Table 3** Initial situation of trip modal split, all individuals—own analysis based on DLR [8]

Territory type	Rural region, medium-sized towns (%)	Rural region, small towns and villages (%)
Case "12a" (elective user, car chosen)	37	34
Case "12b" (elective user, publ. tpt. chosen)	6	5
Case "1" ( $\vartheta_1$ captive car user)	43	51
Case "2" ( $\vartheta_2$ captive PT user, e.g. no car availability or driving license)	2	2
Others (immobile, non-motorized modes etc.)	12	8

German federal passenger transportation law and the local transportation act of the State of Thuringia apply. Comprising the rural/small-town county of 122 k inhabitants (100 inhabitants/km<sup>2</sup>) and the bordering independent town Suhl of 35 k inhabitants (250 inhabitants/km<sup>2</sup>), it is situated at the slopes and hillsides between two low mountain ranges.

The county offers local public road transport (FRS type, dominated by school transportation obligations) on 60 routes, linking about 500 stops in the amount of 4.2 M scheduled kilometers annually—at an average cost of €2.9 per vehicle kilometer. Busses are complemented by four traversing regional rail lines, directed by the federal state, pro rata adding some 0.9 M annual train kilometers. The area's public transport system is challenged due to the geography with deeply incised valleys, resulting in detour factors and stub lines, as well as months with winter road conditions. The transport market is characterized by long-term transport contracts steered by medium-term plans for FRS, directly awarded to internal operators, and only allowing for gradual changes in supply. The possibility of expanding total capacity is limited not only by contract but also by a significant shortage of drivers. Moreover, FRS demand-side incentives by further socially oriented fare reductions have been exhausted—only one sixth of the total costs are still covered by non-school fare revenues. The licensed taxi fleet outside towns is of comparatively small importance in terms of scales and often deployed for paratransit and patient transport. Spontaneous carpooling volume (= Mode 2A) is negligible up to now. The road network infrastructure, on the other hand, is sufficiently dense and qualitatively well-developed on most of the central-place axes. The unit private vehicle count is well above national average.

The data of the initial situation is drawn from a two-mode (private car and FRS) transport model of the trip-end type, based on 2019 socioeconomic data and regional bus passenger counts, subdividing the study area plus a

cordon into 113 zones as depicted. Four types-of-operating days with specific fulfillment time windows, are distinguished. The supply side's *VISUM* implementation, conducted and described by Kiefer et al. [26], models the 2019 regional FRS bus system timetable. Besides legal obligations, school transport, realizing school-day outward and return journeys to educational locations in the required capacities, dominates the network, timetable, and fleet design. Supply is cut back outside the school holidays and during weekends. Analysis of the maximum supply level (= school day, 6:30am/2 pm), nonetheless parametrized by arbitrarily defined minimum acceptable service levels, revealed the limitations of FRS: Already at traffic zone level—about the size of a village or town district—some 27% of O-D pairs exceed 90 min of travel time (access/egress times not yet included), 28% require two or more transfers, and 41% exceed direct car travel times by factor three. Even for this "best case" operating type of day, the fraction of total demand rejected is estimated at more than one fifth. Pursuing Option I, the remaining ( $i, j, \tau$ ) combinations for ~80% of the demand potential (~50% during school holidays, ~30% during weekends) are deemed to be acceptable in terms of service level and would have to be excluded from on-demand offerings.

More than 80% of trips end within the study area and thus have relevance for local transport. The mesoscopic demand, differentiated in a sweeping way by trip party sizes  $\pi$ , was generated on the basis of socioeconomic and regional structural data in conjunction with the *Mobilität in Deutschland 2017* national household travel survey data set for the respective area type [8]. Table 3 illustrates exemplary initial average modal splits of all persons from the two relevant territory types according to Germany's *RegioStaR17* typology, representing 21 and 92 of the 113 zones (32% vs. 68% of the total population). Note that for individuals aged 18 years and more, the share of public transport is only 4.7 and 3.6% including captives, equaling 4,800 and 9,300 trips by adults in total. If the motorization, trip generation rates, modal split of the car and the average trip length are taken as a basis, there are nearly as many private car vehicle kilometers in one day as the public transport companies generate in the entire year.

#### 4.2 On-demand mobility market entry scenario results

For the two regulatory cases described before, a market entry in the form of low to high-adoption level ridesharing in public-private partnership will be examined in the following. It is assumed that up to 60% of elective users could use DRT on a pay-as-you-go basis, i.e.,  $\vartheta_3=0.4$ . In Table 4, the capabilities of hypothetical ridesharing

**Table 4** Comparison of regulatory options and territory types for an average operating day

Regulatory option Territorial type (trip origin)	Option I		Option II	
	6 Medium-sized towns	7 Small towns and villages	6 Medium-sized towns	7 Small towns and villages
Share of potential demand i.e., $(1 - \vartheta_1 - \vartheta_2) \cdot (1 - \vartheta_3)$	33%	32%	33%	32%
Elective demand trip count	51,900	94,400	51,900	94,400
Option I only: residual as of Eq. (3), eligible for DRT	4,700	36,800		
Equivalent #Rides ( $\bar{\pi} = 1.2$ )	3,900	30,700	43,250	87,700
Requested avg. trip length	8 km	13 km	8 km	13 km
Internal car trips originating	50,200	158,500	50,200	158,500
Car trips eligible for DRT	10,500	55,500	50,200	158,500
% Eligible for subsidy	100%	100%	21%	35%
Rides supplied at $\alpha = 0.8\%$ $\leftrightarrow (r_0/c_0, r_1/c_0 \text{ and } \delta)$	84 (2, 0.5, 1.1)	440 (1, 0.5, 1.1)	600 (2, 0.5, 1.05)	1300 (1, 0.5, 1.05)
Compensation k€ (subsidy)	0.18 (100%)	2.2 (100%)	0.8 (21%)	3.0 (35%)
total detour vehicle km	134	580	160	824
Rides supplied at $\alpha = 1.7\%$ $\leftrightarrow (r_0/c_0, r_1/c_0 \text{ and } \delta)$	180 (2, 0.7, 1.2)	940 (1, 0.7, 1.2)	1,200 (2, 0.7, 1.1)	2,700 (1, 0.7, 1.1)
Compensation k€ (Subsidy)	0.5 (100%)	3.3 (100%)	3.2 (3.4%)	9.5 (12.3%)
Total detour vehicle km	378	2,450	680	3,500
Rides supplied $\alpha$ at equilibrium ( $\alpha_0$ ) $\leftrightarrow (r_0/c_0, r_1/c_0 \text{ and } \delta)$	790 7.4% (0.20) (4, 1.6, 1.4)	4,500 8.2% (0.15) (4, 1.4, 1.35)	2,800 3.9% (0.15) (4, 1.4, 1.25)	8,700 5.5% (0.15) (4, 1.2, 1.2)
Compensation k€ (subsidy)	4.6 (52%)	35.8 (41%)	10.5 (9.9%)	60.1 (12%)
Total detour vehicle km	3,100	20,700	3,900	11,300
€/Pkm for $\bar{\pi}' = 2$	0.19	0.12	0.16	0.09

without a service guarantee were calculated for an exemplary operating day and compared for the Option I's fragmentary supply network—restricted to  $(i, j, \tau)$  combinations of the residuals R—as well as Option II's scenario of competing on-demand services, further differentiated by two territorial types of trip origin.

The supplier side's adoption rates  $\alpha$  were estimated for a postulated compensation scheme according to Eqs. (7) to (10). Two exemplary grid points at 0.8% and 1.7% were set at low levels, whereas the back-cast computed ridesharing adoption rate  $\alpha$  at equilibrium state creates a third grid point (Fig. 4). A tabular comparison regarding the SDG achievement is provided in Table 5.

### 4.3 Discussion

By incentivization of the supply side, a considerable floating car traffic potential for ridesharing can be partly leveraged. Higher relative compensations generate more offerings, albeit from a larger “catchment area” and at the expense of higher detour factors. The new service is not subject to an obligation of carriage or presupposes service guarantee, i.e., rides will only take place upon successful supply–demand matchings. The legal basis for this would have to be created. However, the lack of

service guarantees makes a dependable owned car alternative seem questionable.

To fully implement accessibility goals up to the estimated saturation points for different territory types and with a “political” price ceiling of  $c_0$ , an annual budget of €6.2M would be needed in the case of Option I and less than half that amount in Option II—despite the lower target market share of ridesharing. The unit costs per person kilometer vary accordingly.

Up to 44M (Option I) and 96M (Option II) revenue vehicle kilometers could be realized by accepting up to 8.6M (Option I) and 5.5M detour vehicle kilometers to convert and thus reduce solo or weakly utilized car trips. Admittedly, it would have to be checked that detour traffic does not lead to a greater extent through nature reserves and protected areas. Further control options, such as specifications on emission limits for the fleets used for ridesharing, are conceivable and sensible. As a consequence, external costs are thereby parameterized.

The quantity structure developed shows that the proposed targeted integration of on-demand services into the regional transport market does not pose a fundamental threat to public transport; insofar as it is still restricted to (Option I) or subsidized only at (Option II

as a “Quasi-Option I”) O-D pair/fulfillment time window combinations of insufficient level of service. Apart from this, an increase in solo passenger ride-hailing (Alternative 5) compared to today’s cabs in the elective user segment is possible but not considered likely due to lacking incentives.

The rules for selecting eligible  $(i, j, \tau)$  combinations in combination with a certain scarcity-oriented pricing leeway could be implemented in matching apps. This would present the FRS operator with the opportunity of reducing uneconomic parallel service in order to focus on a fixed-interval core network—beyond school transportation—that can be operated efficiently with its forms of production. The questions of matching technologies and how many private or public DRT providers can actually be co-opted remain open.

A system-optimal constrained public–private DRT deployment offers the opportunity of a reduction of uneconomic parallel services upon selection of eligible rides. The revenue opportunities would encourage entrepreneurship. On the other hand, incentivization to such an extent is likely to displace casual ridesharing and causes deadweight losses. Other risks include the regression in terms of standards achieved, for example with regard to barrier-free accessibility.

Despite the precondition of an operational transport model and at additional implementation effort, the assessment scheme does not yet provide practical evidence of a successful introduction. The automated detection of car occupancy levels with non-household passengers is technically demanding and interferes with data privacy. Moreover, the demand responses can go further than shown. E.g., the offering of on-demand services might lead to people going shopping more far away rather than in the local town), thus inducing road traffic. The traffic area studied is not isolable, thus coordination with all adjacent territorial units is essential.

Admittedly, the real-world policy-making is more complicated and may be discontinuous and to an extent inconsistent over time. The example of the *Île-de-France* region (cf. [42]) illustrates that respective incentivization plans are not subject to immediate majority approval and budgeting, and even fundamental decisions can be revised. Whereas a subsidy of ridesharing had been rejected earlier on, in 2021 the region’s transport association could bring itself to co-funding shared rides upon pre-registration. Currently, two daily car rides up to 30 km length will be granted free of charge for monthly pass holders as well as under special circumstances (=severe air pollution) against minimal contribution to expenses for all customers. Concurrently, private car owners—as the ridesharing supply side—are incentivized by a degressive compensation scheme, capped at 150€ total—with rates between €0.5/Passenger-km for the first 100,000 rides and €0.15/Passenger-km beyond one million rides, and to be capped at 150€. This approach would be viable for the study area, too, to curb budgetary risk.

Another issue is the funding that needs to be raised for the refurbishment and renewal of the vast passenger car and minibus fleets (to be) deployed for sharing. Phased-in vehicles shall incorporate low/zero emission technologies and a much higher efficiency level. Moreover, the compliance with road safety standards and the improvement of related key figures is an essential part of transportation sustainability strategies. For example, the Chilean government promotes this goal by a campaign for the collective cabs (“*taxi colectivos*”). It allows access to financing for the renovation of that provide public transportation services in any of the country’s regions [12]. The Shell foundation initiated and supported a study on the improvement of the Eastern African minibuses (“*matatu*”), indispensable for both rural and suburban passenger transport, in terms of economic efficiency, interconnectedness, and eco-friendliness (Shell [40]).

### 5 Conclusions

The article addressed the development steps of a dedicated assessment method in the event that demand-responsive transport is added to an existing rural transport system to a significant yet preconceived extent. The study thus originates from a completely different starting situation for on-demand mobility and its purpose than for the case of full liberalization in conurbations mostly discussed in the literature.

Besides the spatial demand density and a different set of resources for carriage, a crowding out of existing, publicly financed offerings in an unsaturated mobility market should not be the primary concern. At the contrary, resorting to supply-side incentives, a proportion of the high volume of solo car trips could be consolidated while

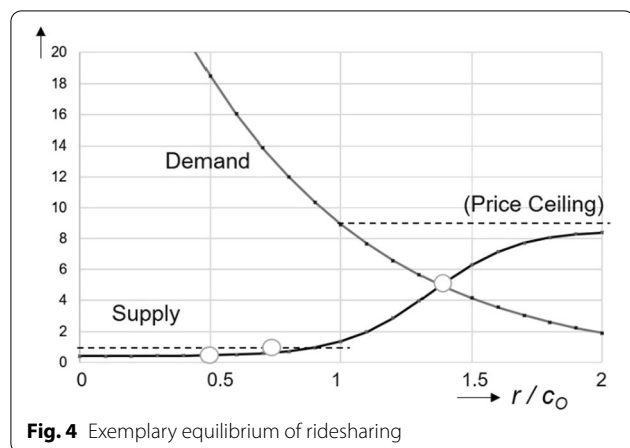

Fig. 4 Exemplary equilibrium of ridesharing

**Table 5** Comparison regarding sustainable development indicators

Indicator	Dimension	Comparison of regulatory options I and II
Share of feasible public mobility options (3.3.1)	Social	With twice as many rides supplies for Option II versus Option I and without the restriction to the residual set R, there is a substantially higher accessibility and availability gain. The estimated share of feasible ( $i, j, \tau$ ) increases by 19 rather than 6 percentage points
Budgetary requirements (3.3.2)	Economic	Assumption: At equilibrium state and assuming $\tilde{\pi}' = 2$ and a fare similar to the current single ticket tariff; transaction costs, particularly costs of running a matching platform and customer service, still have to be included Option I: For more populated territorial type 6, the subsidy could be fully recovered by levying a fixed fare of €2/Person and €.20€/Pkm. For type 7, a tariff of €2 fixed and €.25€/Pkm would still generate a deficit of €4.4 M p.a Option II: The compensation amount for the provider side can be fully compensated with the following pricing below the public transport tariff: Type 6: fixed fare €1/Pers., €1/Pkm; Type 7: 2€/Pers., €2/Pkm
Balance of external costs and GHG emissions (3.3.3)	Environmental	In the equilibrium state, assuming $\tilde{\pi}' = 2$ , the detours of similar size for Option I and II would cause external costs <sup>a</sup> of about €1.3 M and a carbon footprint of about 1,300 tons of additional CO <sub>2</sub> emissions (Ø150g/Veh.km). Nonetheless, there would be a net saving in emissions if only 22% (Option I) or 11% (Option II) of the rideshare passengers were former solo car users. Assuming further that unit accident costs of 3.5 €-cent/passenger kilometer have to be added for every additional passenger taken. The total accident cost per annum ( $\pi = 2$ ) would amount to €2.8 M (Option I) and €6.0 M (Option II)
User benefits of elective demand (3.3.4)	Economic	The annual user benefit at $\tilde{\pi}' = 2$ for Option I was calculated at €10.5 and €15.1 M for Option II. (Value of Time €8/hour, without considering the benefit from omission of transfer needs)
Market share of collective modes (3.3.5)	Environmental	Originating from a high solo car share, Option I is confined to the residual R. At equilibrium point there is an increase of 46%. There is not change for Option II, as the DRT would be operated independently. At equilibrium point, the demand volume is 1.15 times the previous FRS. Due to modal shifts, the market share ratio DRT:FRS will be 1.5
Operational efficiency of on-demand services (3.3.6)	Economic	Even with an equal passenger count per ride, the factual car occupancy level (22) differs much between Options I (1.24) and II (1.47). The reason is that in Option II ridesharing can be offered on virtually all routes and fulfilment time windows without regard to public transport, resulting in lower detour factors

<sup>a</sup> The basic unit external cost of a passenger car with an average occupancy of 1.42 is 13.9 €-cent/vehicle kilometer—according to the updated EU handbook figures for Germany 2016 [10]

levels of service improve in total. However, this may be associated with considerable expense, as demonstrated by the quantity structure of the provided case study.

Due to the persisting great reluctance and resulting delay to introduce DRT and MaaS elements, the research reduced uncertainty with regard to market effects by developing objectifiable criteria and predictive quantity structures for smaller, better manageable areas.

Emphasis was placed on a modal integration, bridging the gap between the private car/van fleets and unmet transport demand through high-adoption ridesharing. This should include the possibility for the user to be offered or to build tailored mobility bundles.

By means of the proposed assessment methods, an operationalizable, consistent, viable trade-off between the three dimensions of sustainability is sought to achieve. The central idea of “digitally guided liberalization with reservation” is to selectively overcome accessibility deficits especially on low-demand routes and or off-peak times, and to allow for more frequent direct transports

while delimiting budgetary and ecological risks. In this context, the sustainability discussion shall be kept apart from the consideration of a sensible competition regime.

The presented set of indicators is decision-oriented, and applicable both at the transactional and macro level. It appears to be suitable to implement all requirements that embrace the concept of sustainability and help to prepare upcoming decisions such as tender procedures and satisfy sustainability goal achievement reporting needs.

Besides the extra-urban object of study, the distinguishing features of the presented assessment scheme are the systematic scanning of the deployment potential versus risks of sustainability target achievement tailored to the conditions of the study area in a geographically rather small, medium-to-thinly populated regions. In view of positive experiences worldwide, this could give rise to more determined steps towards complementing and substituting FRS public transport in under-served (cf. [16]).

Clearly, the data intensive nature of the framework limits its application and transferability. Without the existence of an operational traffic model, an assessment is hardly feasible due to the data requirements. In the run-up to a MaaS introduction, investments should at least be made in the corresponding customer-centric databases, especially when it comes to mesoscopic assessing the reasonable quality of the service levels and the demand segments' preference structures.

The methodology has still limitations. The assumption of only the private car and FRS modes prior to the DRT introduction is only tenable if the attracted demand is still negligible. Also the assumption of fixed trip destinations is a compromise in the absence of usable findings. Further instrumental variables such as zero-emission or reduced-emission vehicle technologies were not considered so far. These can be used to set the right boundary conditions for a successful re-organization of the regional passenger market in the sense of improved sustainability.

Future research could be directed to the application of the presented method to emerging post-pandemic mobility patterns and the assessment of welfare-increasing informal shared forms of transport in rural areas worldwide. To take the set of organizational models (which assume differing roles for the open market and government) proposed by ITF (2020) and apply the evaluation framework to them is a suggested use case. The interplay of different types within the family of mobility service at a time and within multi-modal trip chains is of major interest. The possibilities of ridesharing as a mean of public transport access and egress, supported by an integrated tariff, are not even exhausted. A MaaS App could automatically identify itinerary suggestions. Both the spatial resolution of the model and its boundaries need to increase, given access barriers to pick-up points for pedestrians in the one case and the importance of reaching a critical size of customer bases for the profitability of matching platforms in the other. Another consideration would be to model effects of improved accessibility on vehicle ownership and incremental economic activity.

#### Acknowledgements

The research cooperation with the county office of Schmalkalden-Meiningen, Germany, is gratefully acknowledged. Special thanks are expressed to Mr. Takeru Shibayama, WCTRS SIG G2, and two reviewers for their helpful suggestions.

#### Author contributions

The manuscript is authored by myself—no other contributions. The author read and approved the final manuscript.

#### Funding

Open Access funding enabled and organized by Projekt DEAL.

#### Availability of data and materials

No restrictions.

## Declarations

#### Competing interests

I have no conflicts of interest to disclose.

Received: 30 November 2021 Accepted: 28 August 2022

Published online: 08 September 2022

#### References

- ADAC. (2022). *Der ADAC Mobilitätsindex—Entwicklung nachhaltiger Mobilität in Deutschland*. Munich.
- Amaral, A. M., et al. (Eds.). (2019). *Implications of Mobility as a Service (MaaS) in urban and rural environments*. Business science reference. IGI Global.
- Bahat, O., & Bekhor, S. (2016). Incorporating ridesharing in the static traffic assignment model. *Networks and Spatial Economics*. <https://doi.org/10.1007/s11067-015-9313-7>
- Buzási, A., & Csete, M. (2015). Sustainability indicators in assessing urban transport systems. *Periodica Polytechnica Transportation Engineering*, 43(3), 138–145.
- Bösch, P., Becker, F., Becker, H., & Axhausen, K. W. (2018). *Cost-based analysis of autonomous mobility*. Schriftenreihe IVT, ETH Zürich.
- Clewlow, R. M., & Mishra, G. S. (2017). *Disruptive transportation: The adoption, utilization, and impacts of ride-hailing in the United States*. UCD Report-ITS-RR-17-07, Davis CA.
- Daganzo, C. F., & Ouyang, Y. (2019). A general model of demand-responsive transportation services: From taxi to ridesharing to dial-a-ride. *Transportation Research B*, 126, 213–224. <https://doi.org/10.1016/j.trb.2019.06.001>
- DLR. (2021). *Mobilität in Tabellen, Berlin*. Retrieved from <http://www.mobilitaet-in-tabellen.de>.
- Dobranykyte-Niskota, A., Perujo, A., Jesinghaus, J., & Jensen, P. (2009). Indicators to assess sustainability of transport activities part 2: Measurement and evaluation of transport sustainability performance in the EU27. *JRC Report, Ispra/IT*. <https://doi.org/10.2788/46618>
- European Union. (2020). *Handbook on the external costs of transport—2019-1.1, Luxembourg*.
- Eva M., Mihai F. C., & Munteanu A.V. (2019). Sustainability of the transport sector during the last 20 years: Evidences from a panel of 35 countries. In 19th SGEM Conference Proceedings (Vol. 19, No. 5.1, pp. 687–694).
- Government of Chile. (2021). *Programa de renovación de taxis colectivos (Renueva tu Colectivo), Santiago de Chile*. Retrieved from: <https://www.chileatiende.gob.cl/fch/as/43671-programa-de-renovacion-de-taxis-colectivos-renueva-tu-colectivo>.
- Grush, B., & Niles, J. (2017). Transit leap: A deployment path for shared use autonomous vehicles that supports sustainability. In: Meyer/Shahen (Eds.), *Disrupting mobility; Springer lecture notes in mobility* (pp. 291–305).
- Haferkamp J., & Ehmke, J. F. (2020). *Evaluation of anticipatory decision-making in ride-sharing services working paper No. 4/2020*, Otto von Guericke University Magdeburg.
- Häme, L. (2013). *Demand-responsive transport: Models and algorithms*. Doctoral Dissertation, Aalto University School of Science Publication Series No. 80, Helsinki.
- Hebart, J. (2022). *Regulation of ride-sharing services in Germany—Insights from China and the USA*. Győr: European Transport Congress.
- Heinitz, F. (2022). Flexible integrated transport systems' potential to unleash net benefits in rural areas. In C. Ha-Minh, A. M. Tang, T. Q. Bui, X. H. Vu, & D. V. K. Huynh (Eds.), *Emerging technologies and applications for green infrastructure. Lecture notes in civil engineering*. (Vol. 203). Singapore: Springer. [https://doi.org/10.1007/978-981-16-7160-9\\_164](https://doi.org/10.1007/978-981-16-7160-9_164)
- Hensher, D. A., Mulley, C., Nelson, J. D., Ho, C., Smith, G., & Wong, Y. (2020). *Understanding mobility as a service (MaaS)*. Elsevier.
- Hensher, D. A., Mulley, C., & Nelson, J. D. (2021). Mobility as a service (MaaS)—Going somewhere or nowhere? *Transport Policy*, 111, 153–156.
- IEA International Energy Agency. (2022). *A 10-Point Plan to Cut Oil Use—Fuel Report. Paris*. Retrieved from <https://www.iea.org/reports/a-10-point-plan-to-cut-oil-use>.

21. Imhof, S., Frölicher, J., & Arx, W. V. (2020). Shared autonomous vehicles in rural public transportation systems. *Research in Transportation Economics*, 83, 100925. <https://doi.org/10.1016/j.retrec.2020.100925>
22. ITF. (2021). *Integrating public transport into mobility as a service: Summary and conclusions, itf roundtable reports*, no. 184. Paris: OECD Publishing.
23. Jacob, S., & Roet-Green, R. (2021). Ride solo or pool: Designing price-service menus for a ride-sharing platform. *European Journal of Operational Research*, 295(3), 1008–1024.
24. Kagho, G., Hensle, D., Balac, M., Freedman, J., Twumasi-Boakye, R., Broadus, A., Fishelson, J., & Axhausen, K. (2021). Demand responsive transit simulation of Wayne County, Michigan. *Transportation Research Record*. <https://doi.org/10.1177/03611981211031221>
25. Khavarian-Garmsir, A. R., Sharifi, A., & HajianHosseinAbadi, M. (2021). The social, economic, and environmental impacts of ridesourcing services: A literature review. *Future Transportation*, 1(2), 268–289. <https://doi.org/10.3390/futuretransp1020016>
26. Kiefer, L., Saenger, K., Seifert, K., & Wendt, M. (2020). *Entwicklung eines Konzepts für bedarfs-getriebene Verkehre im Landkreis Schmalkalden-Meiningen*. Project Report, FH Erfurt.
27. Knieps, G. (2013). *Der Irrweg regulatorischer Marktsplattung: Zur Novelle des PBefGs in Deutschland*. Institut für Verkehrswissenschaft und Regionalpolitik, No. 145, Freiburg/Brsq.
28. Knieps, G. (2018). ÖPNV in der App-Ökonomie: Chancen und Risiken. *Zeitschrift für Verkehrswissenschaft*, 89(2), 140–150.
29. Liebchen, C., Lehnert, M., Mehler, C., & Schiefelbusch, M. (2020). Ridepooling-Effizienz messbar machen. *Der Nahverkehr*, 9(2020), 18–21.
30. Litman, T. (2021). *Well measured developing indicators for sustainable and livable transport planning*. Victoria Transport Policy Institute.
31. Manzini, R., & Pareschi, A. (2012). A decision-support system for the car pooling problem. *Journal of Transportation Technologies*. <https://doi.org/10.4236/jtts.2012.22011>
32. Middleton, S., Schroeckenthaler, K., Papayannoulis, V., & Gopalakrishna, D. (2021). *Analysis of travel choices and scenarios for sharing rides (FHWA-HOP-21-011)*. Washington DC.
33. Mounce, R., Wright, S., Emele, D. C., Zeng, C., & Nelson, J. D. (2018). A tool to aid redesign of flexible transport services to increase efficiency in rural transport service provision. *Journal of Intelligent Transportation Systems*, 22(2), 175–185.
34. Mounce, R., Beecroft, M., & Nelson, J. (2020). On the role of frameworks and smart mobility in addressing the rural mobility problem. *Research in Transportation Economics*, 83, 100956. <https://doi.org/10.1016/j.retrec.2020.100956>
35. Nocera, S., & Tsakarestos, A. (2004). Demand responsive transport systems for rural areas in Germany. *Traffic Engineering and Control*, 45(10), 378–383.
36. Ott, K. (2014). Institutionalizing strong sustainability: A Rawlsian perspective. *Sustainability*, 6, 894–912. <https://doi.org/10.3390/su6020894>
37. Pangbourne, K., Mladenović, M. N., Stead, D., & Milakis, D. (2020). Questioning mobility as a service: Unanticipated implications for society and governance. *Transportation Research A*, 131, 35–49.
38. Schaller, B. (2017). *Unsustainable? The growth of app-based ride services and traffic, travel and the future of New York City*. Report—Schaller Consulting, New York City.
39. Sdoukopoulos, A., Pitsiava-Latinopoulou, M., Basbas, S., & Papaioannou, P. (2019). Measuring progress towards transport sustainability through indicators: Analysis and metrics of the main indicator initiatives. *Transportation Research Part D*, 67, 316–333.
40. Shell Foundation. (2021). *Easy Matatu—Travel made safer and faster*. Report, London. Retrieved <https://shellfoundation.org/app/uploads/2021/03/Easy-Matatu-learning-report.pdf>.
41. Simons, J., Wacker, B., Bossert, A., & Schlüter, J. (2021). Verkehrsökonomische Analyse von Minibusverkehren in der Metropolregion Kapstadt und in den Minenstadt Rustenburg in Südafrika. *Zeitschrift für Verkehrswissenschaft*, 91(1), 1–24.
42. Société Web Editions. (2021). *Île-de-France: êtes-vous concernés par la gratuité des trajets de covoiturage?* DemarcheAdministratives News Portal. Saint Chamond. Retrieved from <https://demarchesadministratives.fr/actualites/ile-de-france-etes-vous-concernes-par-la-gratuite-des-trajets-de-covoiturage>.
43. Storch, D. M., Timme, M., & Schroeder, M. (2021). Incentive-driven transition to high ride-sharing adoption. *Nature Communication*, 12, 3003. <https://doi.org/10.1038/s41467-021-23287-6>
44. United Nations. (2015). *Transforming our world: The 2030 agenda for sustainable development, resolution A/RES/70/1* New York.
45. UNECE. (2020). *Measuring and monitoring progress towards the sustainable development goals, United Nation Report ECE/INF/2020/5*, Geneva.
46. UNSTATS. (2021). *Global indicator framework for the sustainable development goals and targets of the 2030 agenda for sustainable development. Resolution 68/261*, New York.
47. Wilson, M. C., & Wu, L. (2017). The problems of weak sustainability and associated indicators. *International Journal of Sustainable Development & World Ecology*. <https://doi.org/10.1080/13504509.2015.1136360>
48. Yang, L., van Dam, K. H., & Zhang, L. (2020). Developing goals and indicators for the design of sustainable and integrated transport infrastructure and urban spaces. *Sustainability*, 12, 9677. <https://doi.org/10.3390/su1229677>
49. Yin, B., Liu, L., Coulombel, N., & Vigiúí, N. (2017). Evaluation of ridesharing impacts using an integrated transport land-use model: A case study for the Paris region. *Transportation Research Procedia*, 27, 824–831.
50. Yuanyuan, Z., & Yuming, Z. (2018). Examining the relationship between household vehicle ownership and ridesharing behaviors in the United States. *Sustainability*, 10(8), 2720.
51. Zhao, X., Ke, Y., Zuo, J., Xiong, W., & Wu, P. (2020). Evaluation of sustainable transport research in 2000–2019. *Journal of Cleaner Production*, 256, 120404.

## Publisher's Note

Springer Nature remains neutral with regard to jurisdictional claims in published maps and institutional affiliations.

**Submit your manuscript to a SpringerOpen® journal and benefit from:**

- Convenient online submission
- Rigorous peer review
- Open access: articles freely available online
- High visibility within the field
- Retaining the copyright to your article

---

Submit your next manuscript at ► [springeropen.com](https://www.springeropen.com)

---